



# GENUINE PARTS

## INSTALLATION INSTRUCTIONS

**DESCRIPTION:** Step Rails

**APPLICATION:** Titan

**PART NUMBER:** 999T6 W4100 (Crew Cab-Chrome)  
 999T6 W4200 (King Cab-Chrome)  
 999T6 W4350 (Crew Cab-Graphite)  
 999T6 W4450 (King Cab-Graphite)  
 999T6 W4900 (Single Cab-Black)

**KIT CONTENTS:**

Item	Qty.	Part Description
A.1	2	Step Rails Crew Cab
A.2	2	Step Rails King Cab
A.3	2	Step Rails Single Cab
B	6	Brackets
C	12	Bolts 25mm Length
D	12	Bolts 20mm Length
E	2	Spacer Plate
F	1	Installation Instruction Replatement Template

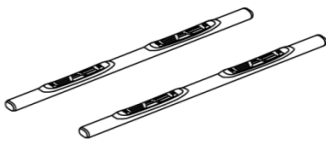

A.1



A.2

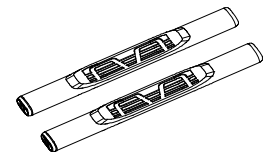

A.3

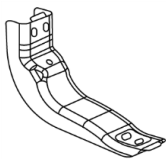

B

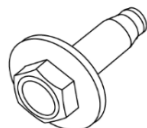

C

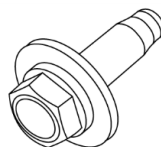

D

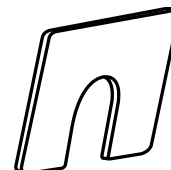

E

Crew Cab Only



F

**TOOLS REQUIRED:**

- Ratchet
- 12mm Deep-Well Socket with 3/4" Extension
- Torque Wrench

**PRE-INSTALLATION WARNINGS, CAUTIONS, CRITICAL STEPS, and NOTES:**

- Study illustrations and read the instructions carefully before attempting assembly.
- Please take special attention to spacer plate included in kit. This is very important item that must be installed.
- Always wear safety glasses while working under any vehicle

**INSTALLATION PROCEDURE:** (continue)

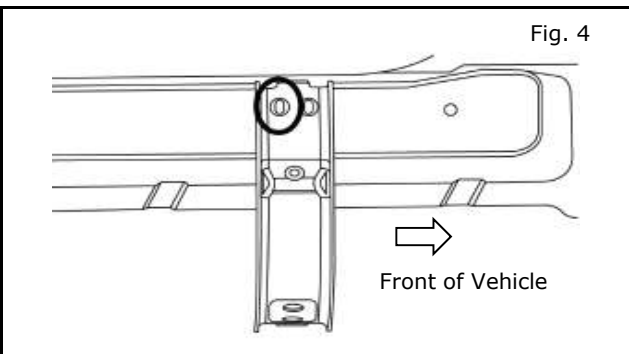
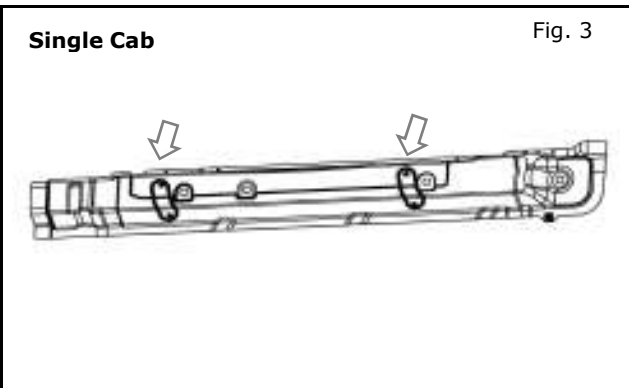
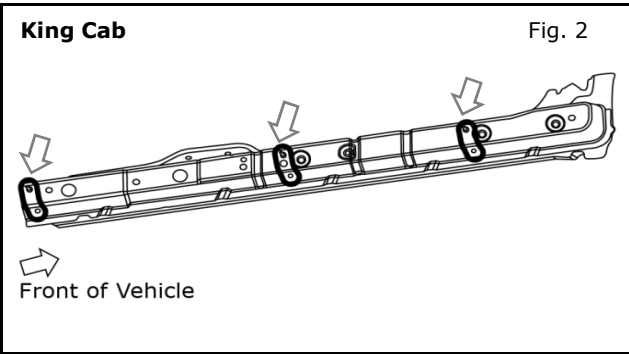
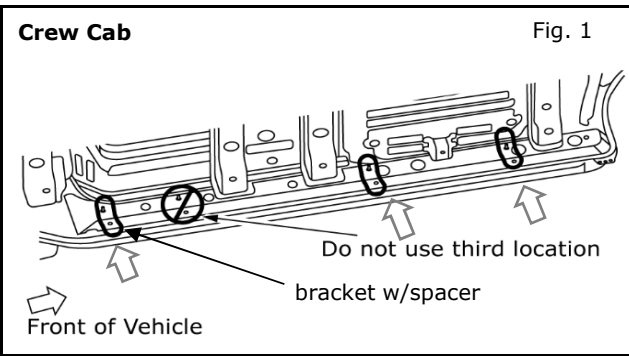

- 1) Install Brackets - Driver's Side
  - a) Locate 3 weld nut hole locations in frame. Weld nuts sets are located in front, middle, and rear of vehicle frame as shown in illustration.

**NOTE:**

- There are four (4) weld nuts locations on the Crew Cab. From the front of the vehicle, use the 1st, 2nd, and 4th locations.

- There are three (3) weld nut locations on the King Cab. From front of the vehicle, use 1st, 2nd, and 3rd location.

- There are two (2) weld nut locations on the Single Cab.

- b) Locate one bracket to body sill in front location on driver side - use hole on left side of bracket. This is hole to rear of vehicle.

**INSTALLATION PROCEDURE:** (continue)

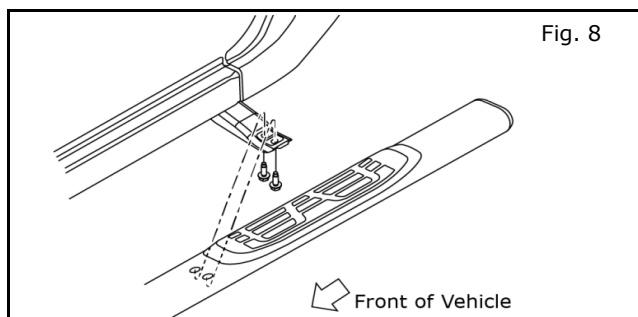
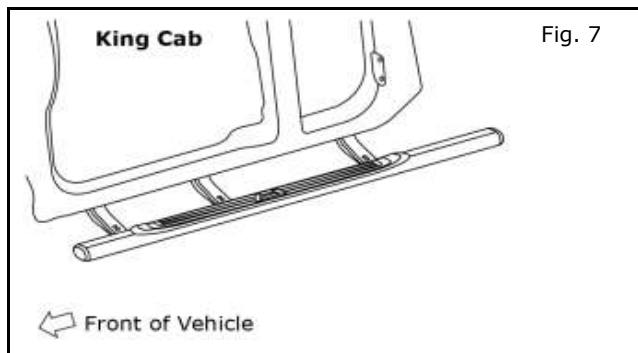
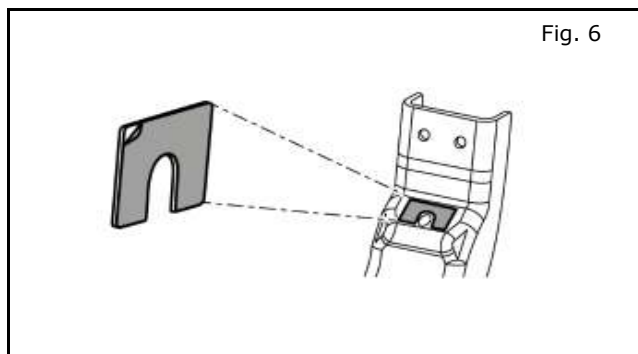
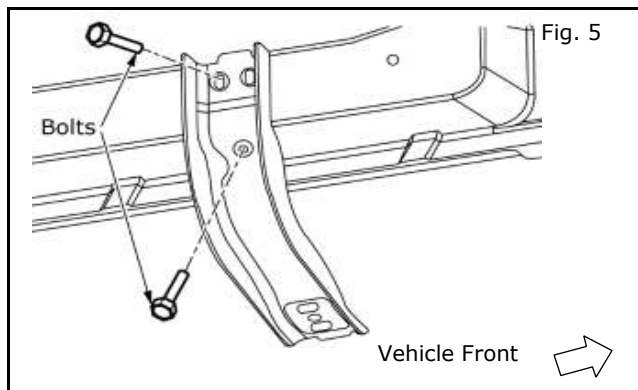

- c) Secure with two 25mm length bolts.
- d) Repeat for other two locations on driver's side.

**NOTE:**

**For CREW CAB application, proceed to next step. For KING CAB application, proceed to Step 2.**

**Crew Cab Only: (step e & f)**

- e) Peel adhesive backing from spacer plate and apply spacer to flat surface on bracket around attachment slot (see fig 5). Do not cover edges of slot
- f) Attach bracket with spacer to third most rear attachment location (see fig. 1).

**IMPORTANT NOTE:**

**Spacer must be installed on rear most bracket only.**

- 2) Install Step Rail
  - a) Position step rail on brackets. Ensure step rail is positioned correctly and correct end is toward front of vehicle.
    - i) King Cab- Step pad should be offset towards front of vehicle.
    - ii) Crew Cab - Largest pad should be at front of vehicle.
    - iii) Chrome and Graphite left side rails (Driver side) are marked with -LH- sticker located bottom of rail.
  - b) Secure step rail to each bracket with two 20mm length bolts.

**INSTALLATION PROCEDURE:** (continue)

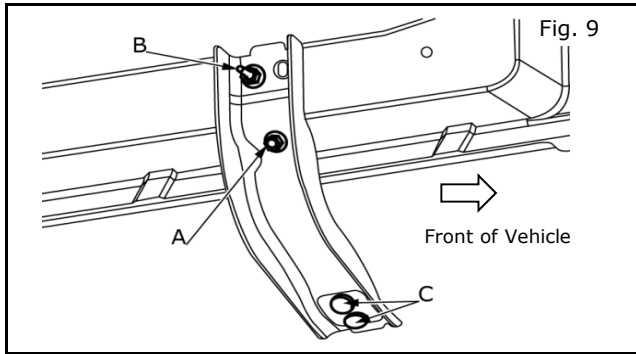

- 3) Tighten bolts.
  - a) Using 25mm long socket, tighten bolt holding bracket to frame to 24 N-m (17.3 ft-lb; 212 in-lb.)
  - b) Using 20mm long socket, tighten bolts holding step rail to each bracket to 14 N-m (10.5 ft-lb; 124 in-lb)

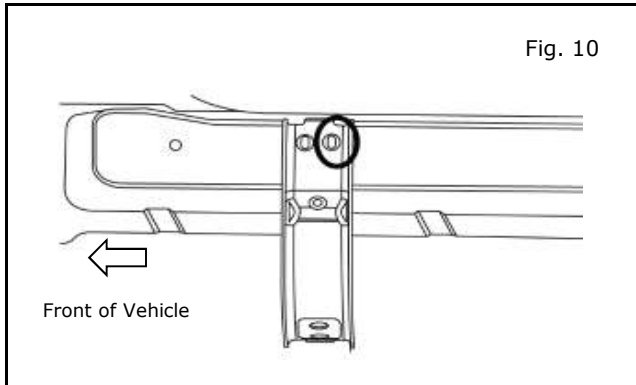

- 4) Repeat above steps for passenger side, except use slot on right side when installing brackets. This is slot to rear of vehicle.

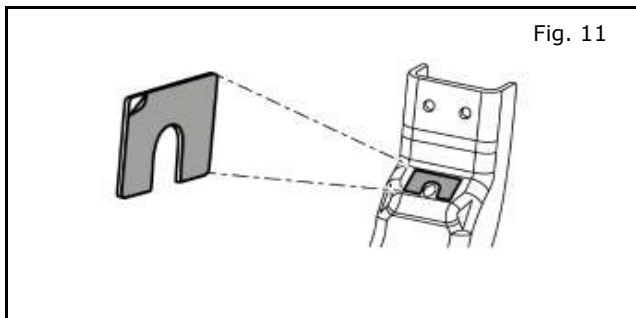

**NOTE:**  
For **CREW CAB** application only, follow **Step 5.**

- 5) Repeat steps 1e) and 1f) from driver side to rear bracket attachment location.

**IMPORTANT NOTE:**  
Spacer must be installed on rear most bracket only.

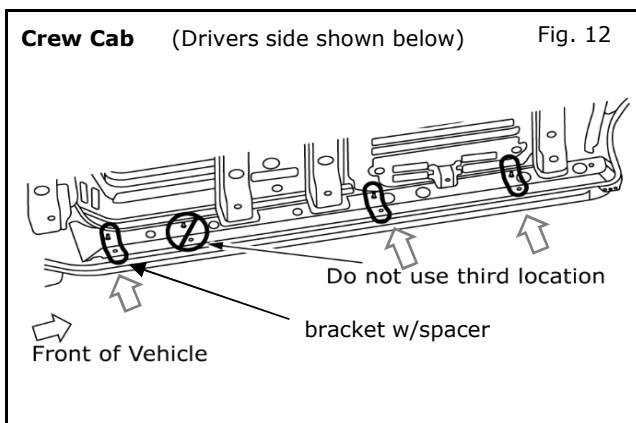

**ACCESSORY CHECK:**

- Verify that spacer plate is installed to rear most brackets.
- Check all **torque** values. (Reference related steps and figures)